

ESSMANN® Double Flaps

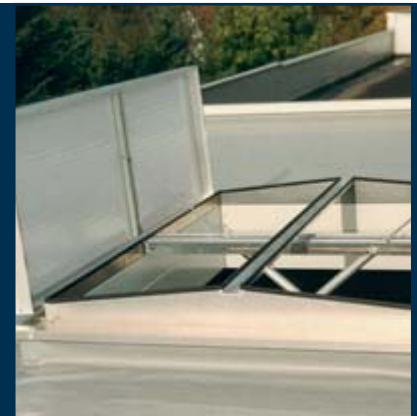

Product Description

ESSMANN® Double Flaps

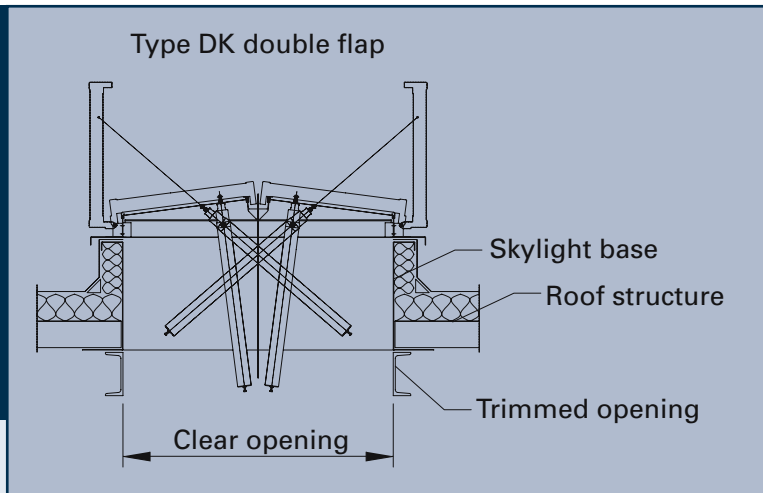

ESSMANN double flaps are ideal for complying with fire prevention requirements, for daily aeration and ventilation and for providing natural daylight.

The longitudinal sides of the flaps open to an angle of more than 90°, exposing the whole cross-section of the unit for ventilation. The air replacement performance of this design is superb. The flaps slope towards the centre drain pipe for self-cleaning and water drainage.

The double flap also complies with the fire prevention requirements of DIN EN 12101-2 for a smoke and heat extraction system. The double flap comes complete with an Open/Close control mechanism. 24 V motors can also be installed to use ESSMANN double flaps for geometric smoke extraction.

An optional transparent pane is available for ESSMANN double flaps, making them ideal for providing natural daylight.

The optional single-blade version of the ESSMANN double flap is flat, making it ideal for glass structures, gable roofs and sheds.

In addition to polycarbonate, the flaps are also available in aluminium or a combination of aluminium, steel and insulation to meet strict soundproofing requirements.

Further information can be found at www.essmann.de

ESSMANN GmbH
 Im Weingarten 2
 D-32107 Bad Salzufflen
 Telephone +49 (0)5222.791-0
 Telefax +49 (0)5222.791-236
 E-Mail info@essmann.de
www.essmann.de