

## ESSMANN® Frame for Arcade Rooflight ESSMANN® Frame Safety Connection

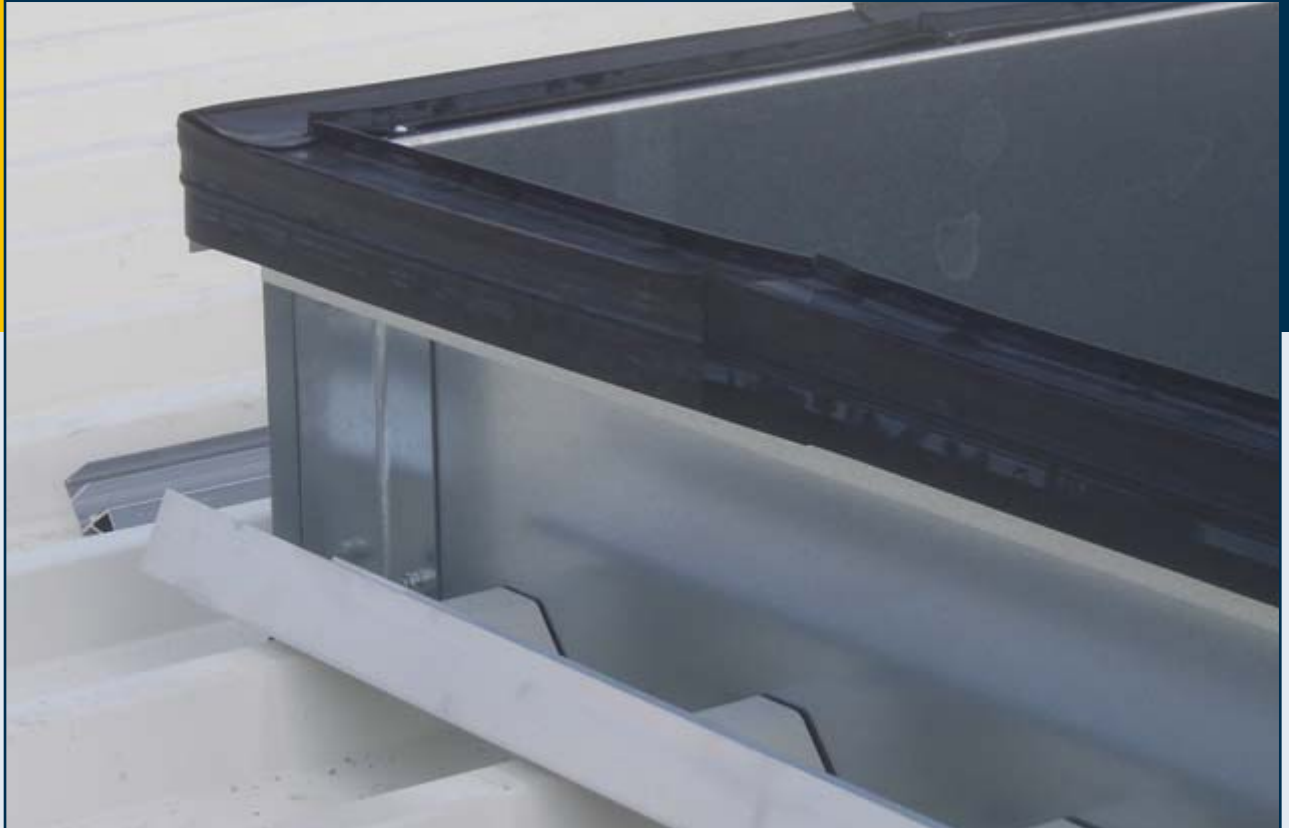

## Product Description

### ESSMANN® Frame for Arcade Rooflight ESSMANN® Frame Safety Connection

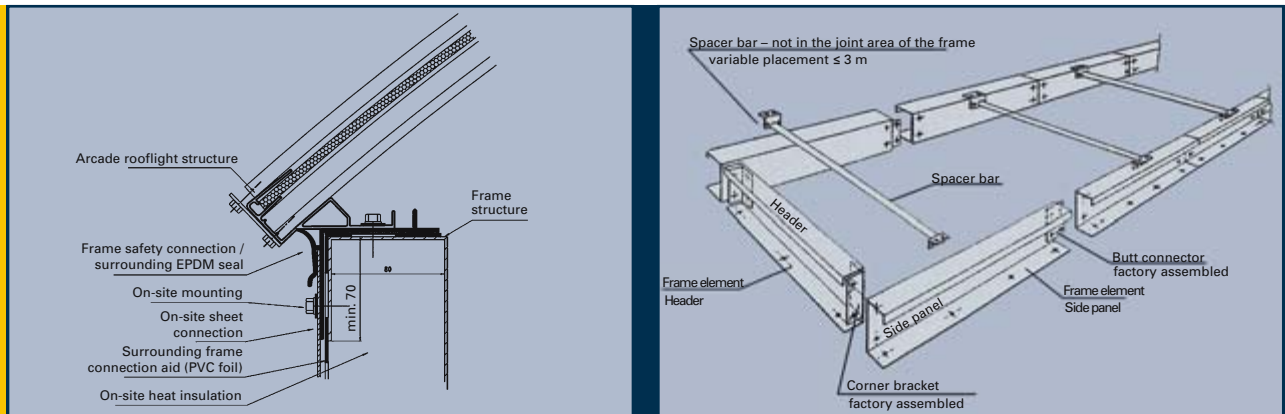

#### ESSMANN frame for arcade rooflight

ESSMANN frames for arcade rooflights are made of 2 or 3 mm galvanised sheet steel depending on the technical requirements. 2mm frame elements can be mounted up to a truss spacing of 6 m; 3 mm elements are installed up to truss spacing of 8 m. The frame element splay is rectangular in design.

ESSMANN frames for arcade rooflights are structured as follows: Butt connectors and angle pieces are used to connect the individual frame elements. The brackets included in the scope of supply are used to mount the assembled frame on the relevant support. The spacer bars belonging to the frame ensure compliance with static requirements and serve as a mounting aid. They are mounted at a maximum distance of 3 m from each other.

#### ESSMANN frame safety connection

The optional ESSMANN frame safety connection links the critical connection point of the on-site roofing membrane in the area of the frame to the arcade rooflight connection.

The geometry and flexibility of the frame safety connection enable the roofer to design perfect and secure frame connections for sheeting and bitumen and plastic membranes. The frame and arcade rooflight can be mounted in one step, irrespective of the roofing membrane.

The frame safety connection is made of EPDM and is fitted to the upper side of the frame, fixed and flashed with the base section of the arcade rooflight system prior to assembling the frame seal and the arcade rooflight.

The arcade rooflight can be assembled directly afterwards.

#### The product features at a glance:

- perfect and secure frame connection
- secure storage of the roof connections
- thermal separation of metal sheeting
- the frame and arcade rooflight can be mounted in one step, irrespective of the roofing membrane
- easy corner profiles
- no corner pieces required
- flexible connection
- leak-proof butt joints without the need for additional seals
- system-compatible flash rail without the need for additional seals
- no additional splays required in the connecting sheets
- no damage to the upper roof membrane as the frame can be connected following assembly of the arcade rooflight

**The instructions for installing roof sealing systems must be observed at all times.**



ESSMANN frame safety connection



ESSMANN frame safety connection

Further information can be found at [www.essmann.de](http://www.essmann.de)

ESSMANN GmbH  
Im Weingarten 2  
D-32107 Bad Salzufflen  
Telephone +49 (0) 5222.791-0  
Telefax +49 (0) 5222.791-236  
E-Mail [info@essmann.de](mailto:info@essmann.de)  
[www.essmann.de](http://www.essmann.de)

A member of the **ESSMANN GROUP**.