

ESSMANN® egress and access hatches for skylight domes

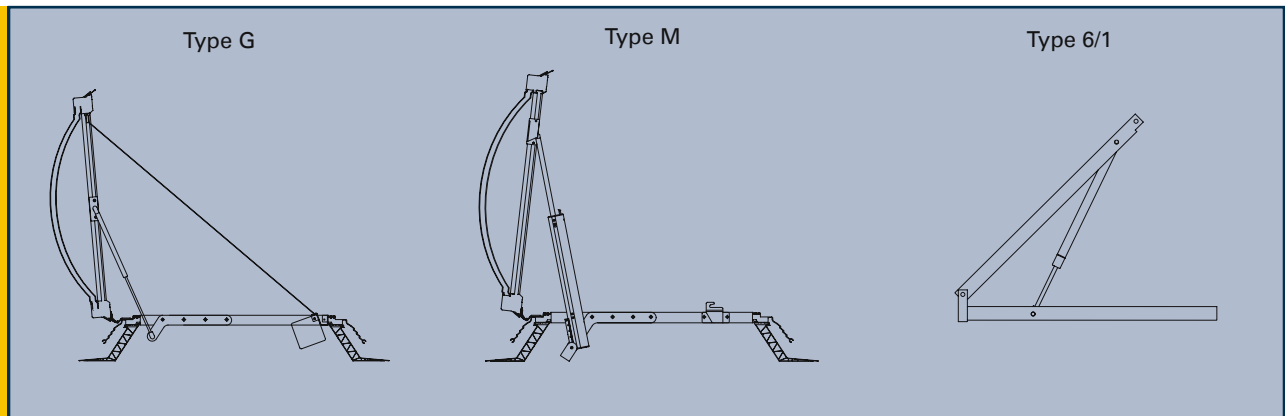

Product Description

ESSMANN® hatches and access hatches



ESSMANN egress hatch, type G (gas spring)

- two pressurised gas springs on the side for easy and controlled opening
- highly effective damping of all pressurised gas springs ensures the secure fixation of the opened skylight dome
- the skylight dome is easy to close thanks to the hard-wearing plastic belt stored in a rope roller on the right-hand side of the hatch
- secure and convenient catch for locking the skylight dome

ESSMANN egress hatch, type M (servomotor)

- the skylight dome opens and closes comfortably with the help of two servomotors fitted to the side
- the motors are designed for 24 V or 230 V mains voltage. An additional power pack for the 230V motor version is included in the scope of supply.
- the positioning of the drives is determined at the factory to guarantee that the skylight dome opens and closes evenly and smoothly
- convenient aeration and ventilation option

ESSMANN egress hatch, type M, for use as a smoke extraction (SE) system, regional building ordinance compliant, for staircases

The type M egress hatch can optionally be used as a smoke extraction system in a set consisting of the type M hatch, a (2 or 3-skinned) ESSMANN **plus** skylight dome and an ETZ 24V/2M-1G staircase control centre.

ESSMANN egress hatch, type 6/1 (for retrofitting)

The type 6/1 egress hatch incorporates a gas spring-driven hold-open arm as a manually-operated lifting aid. This type of egress hatch is only available as a set for retrofitting existing ESSMANN skylight domes, types **classic**, 810 or older.

Available sizes			
Nominal size cm x cm	Type G*	Type M*/ Type M as SE*	Type 6/1 for retro- fitting
60/90	●	—	—
60/120	●	—	—
70/137	●	—	—
80/80	●	—	●
90/90	●	—	●
90/120	●	●	●
100/100	●	●	●
100/150	●	●	●
100/200	●	●	—
100/250	●	●	—
120/120	●	●	●
120/150	●	●	—
120/180	●	●	—
120/240	●	●	—
125/125	●	●	●
150/150	●	●	—
150/180	●	●	—

* Other intermediate sizes up to max. 150 / 180 can be manufactured at any time on request.

All ESSMANN egress hatches are pre-assembled at the factory and supplied in combination with the ESSMANN **plus** skylight dome. The opening width depends on the type of egress hatch and size of the skylight dome.

All ESSMANN egress hatches can also be designed as access hatches for allowing access from the outside (e.g. in suspended ceilings).

Further information can be found at www.essmann.de

ESSMANN GmbH
Im Weingarten 2
D-32107 Bad Salzufflen
Telephone +49 (0) 5222.791-0
Fax +49 (0) 5222.791-236
E-Mail info@essmann.de
www.essmann.de

A member of the ESSMANN GROUP.